

SPECIFICATION FOR APPROVAL

REF : 20091008-A

PAGE: 1

| | | | |
|------------|--------------------------------|----------------|------------------|
| PROD. NAME | SHIELDED SMD POWER INDUCTOR | ABC'S DWG NO. | SH6028□□□□L□-□□□ |
| | | ABC'S ITEM NO. | |

I . CONFIGURATION & DIMENSIONS :

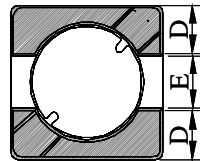
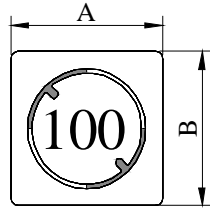

- A : 6.80 ±0.2 m/m
- B : 6.80 ±0.2 m/m
- C : 2.80 ±0.2 m/m
- D : 2.30 typ. m/m
- E : 2.20 typ. m/m
- G : 2.10 ref. m/m
- H : 7.30 ref. m/m
- I : 2.60 ref. m/m
- R : 2.70 ref. m/m

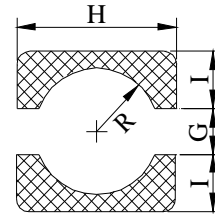

(PCB Pattern suggestion)

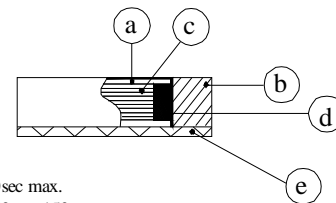
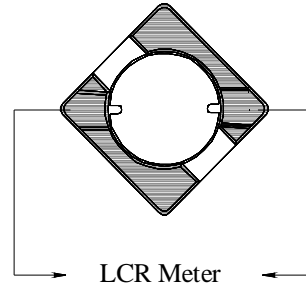

II . SCHEMATIC DIAGRAM :

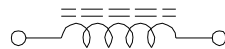

III . MATERIALS :

- a . Core : Ferrite DR core
- b . Core : Ferrite RI core
- c . Wire : Enamelled copper wire (Class H)
- d . Adhesive : Epoxy resin
- e . Terminal : Ag/Ni/Sn
- f . Remark : Products comply with RoHS' requirements

Peak Temp : 250°C max.
 Max. Peak Temp - 5°C : 30sec max.
 Max time above 217°C : 60sec-150sec max.

IV . GENERAL SPECIFICATION :

- a . Temp. rise : 30°C max.
- b . Storage temp. : -40°C ----+125°C
- c . Operating temp. : -40°C ----+105°C
- d . Resistance to solder heat : 250°C .10 secs.

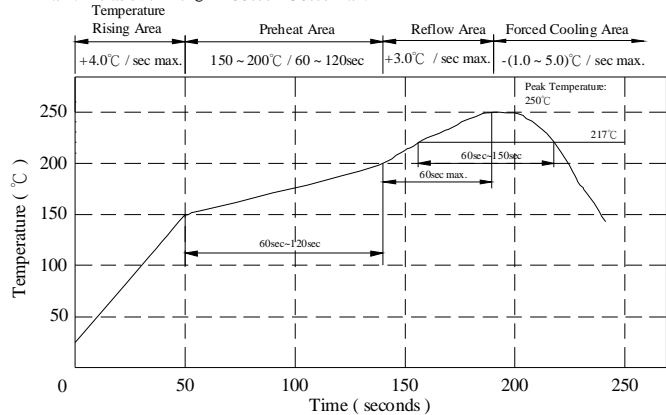

AR-001A

SPECIFICATION FOR APPROVAL

REF : 20091008-A

PAGE: 2

| | | | |
|------------|--------------------------------|----------------|------------------|
| PROD. NAME | SHIELDED SMD POWER INDUCTOR | ABC'S DWG NO. | SH6028□□□□L□-□□□ |
| | | ABC'S ITEM NO. | |

V . ELECTRICAL CHARACTERISTICS :

| DWG No. | Inductance (μ H) | SRF (MHz) typ. | RDC (m Ω) | | Irms (A) max. | Isat (A) typ. |
|------------------|--------------------------|----------------------|----------------------|--------|---------------------|---------------------|
| | | | typ. | max. | | |
| SH60282R5YL□-□□□ | 2.5 \pm 30% | 50 | 19.0 | 25.0 | 2.80 | 3.00 |
| SH60283R3YL□-□□□ | 3.3 \pm 30% | 45 | 21.0 | 28.0 | 2.50 | 2.60 |
| SH60283R9YL□-□□□ | 3.9 \pm 30% | 40 | 24.0 | 32.0 | 2.45 | 2.30 |
| SH60285R0YL□-□□□ | 5.0 \pm 30% | 38 | 27.0 | 36.0 | 2.40 | 2.10 |
| SH60286R0YL□-□□□ | 6.0 \pm 30% | 35 | 30.0 | 40.0 | 2.30 | 2.00 |
| SH60287R3YL□-□□□ | 7.3 \pm 30% | 30 | 38.0 | 52.0 | 2.20 | 1.85 |
| SH60288R6YL□-□□□ | 8.6 \pm 30% | 28 | 42.0 | 56.0 | 2.10 | 1.82 |
| SH6028100YL□-□□□ | 10.0 \pm 30% | 25 | 47.0 | 65.0 | 2.00 | 1.70 |
| SH6028150YL□-□□□ | 15.0 \pm 30% | 22 | 58.0 | 78.0 | 1.70 | 1.30 |
| SH6028220YL□-□□□ | 22.0 \pm 30% | 20 | 88.0 | 115.0 | 1.40 | 1.08 |
| SH6028330YL□-□□□ | 33.0 \pm 30% | 18 | 120.0 | 155.0 | 1.15 | 0.92 |
| SH6028470YL□-□□□ | 47.0 \pm 30% | 16 | 185.0 | 235.0 | 0.92 | 0.72 |
| SH6028680YL□-□□□ | 68.0 \pm 30% | 15 | 245.0 | 300.0 | 0.80 | 0.60 |
| SH6028101YL□-□□□ | 100.0 \pm 30% | 14 | 385.0 | 500.0 | 0.58 | 0.55 |
| SH6028151YL□-□□□ | 150.0 \pm 30% | 13 | 540.0 | 680.0 | 0.50 | 0.42 |
| SH6028221YL□-□□□ | 220.0 \pm 30% | 12 | 660.0 | 820.0 | 0.45 | 0.36 |
| SH6028331YL□-□□□ | 330.0 \pm 30% | 10 | 1100.0 | 1400.0 | 0.37 | 0.27 |
| SH6028471YL□-□□□ | 470.0 \pm 30% | 9 | 1650.0 | 2100.0 | 0.27 | 0.22 |
| SH6028681YL□-□□□ | 680.0 \pm 30% | 8 | 2450.0 | 3100.0 | 0.22 | 0.20 |
| SH6028102YL□-□□□ | 1000.0 \pm 30% | 7 | 3600.0 | 4500.0 | 0.15 | 0.17 |

- 1). □ : Packaging Information... [A] : Bulk [B] & [C] : Taping Reel
- 2). "- □□□ " : Reference code
- 3). Inductance Test Freq. : 100KHz / 0.1V
- 4). Irms base on Temp. rise 30°C max.
- 5). Isat base on $\Delta L/L0A = 35\%$ typ.

@ Inductance VS. DC Current Curve

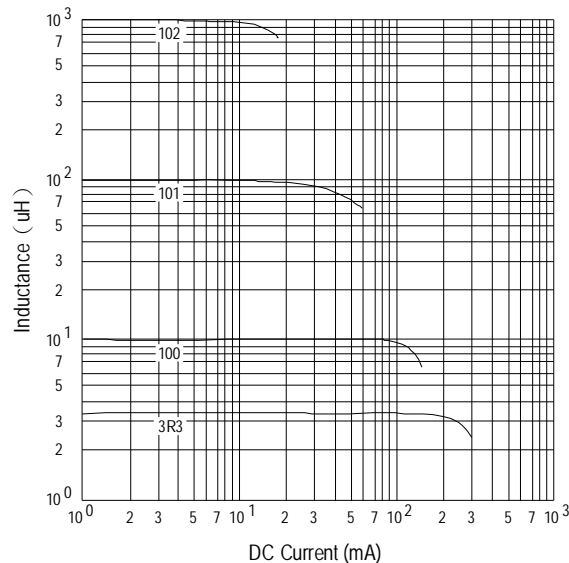

AR-001A

SPECIFICATION FOR APPROVAL

REF : 20091008-A

PAGE: 3

| | | | |
|------------|--------------------------------|----------------|-------------------|
| PROD. NAME | SHIELDED SMD POWER INDUCTOR | ABC'S DWG NO. | SH6028□□□□□L□-□□□ |
| | | ABC'S ITEM NO. | |

VI . PACKAGING INFORMATION :

(1) Configuration

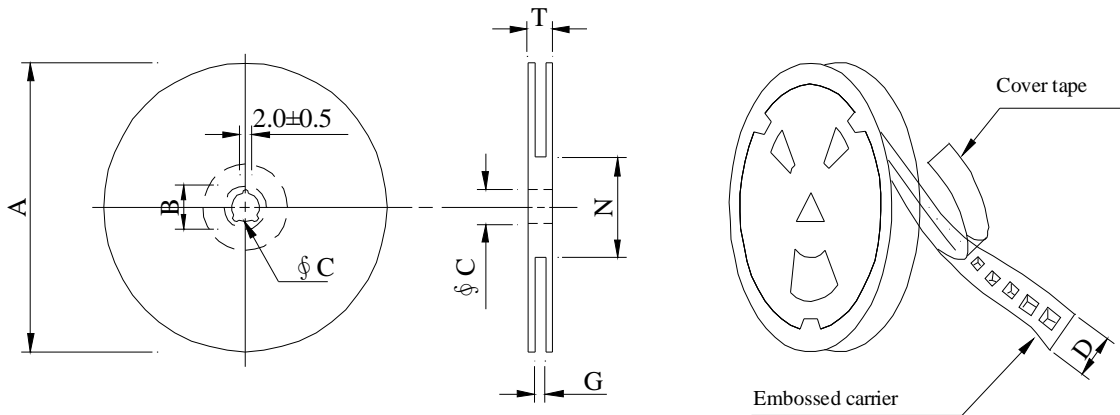

※Carrier tape width : D

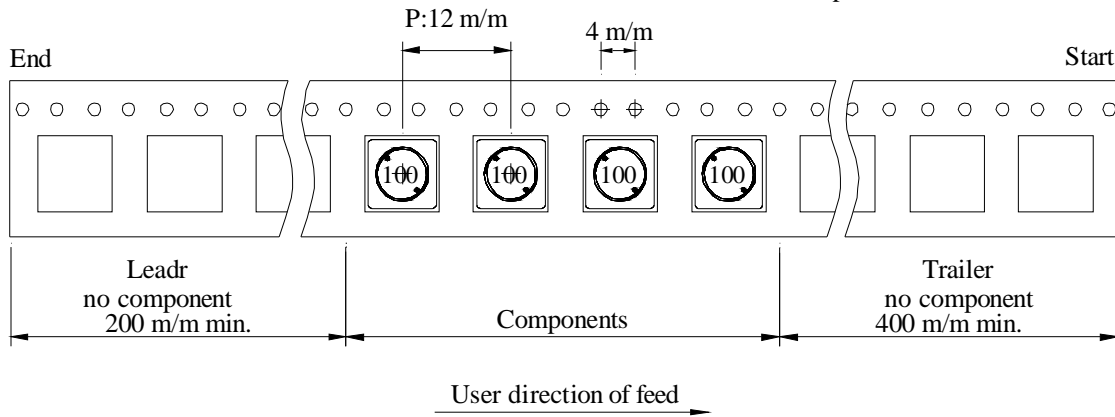

(2) Dimensions

Unit:m/m

| Style | A | B | C | D | G | N | T |
|---------|-----|--------|--------|----|------------------|------------------|------|
| 07 - 16 | 178 | 21±0.8 | 13 | 16 | 18 ⁺⁰ | 50 ⁻⁰ | 20.5 |
| 13 - 16 | 330 | 21±0.8 | 13±0.5 | 16 | 18 ⁺⁰ | 50 ⁻⁰ | 22.4 |

(3) Q'TY & G.W. Per package

| Series | Inner : Reel | | | Outer : Carton | | |
|--------|--------------|-----------|---------|----------------|-----------|--------------|
| | Q'TY (pcs) | G.W. (gw) | Style | Q'TY (pcs) | G.W. (Kg) | Size (cm) |
| SH6028 | 500 | 300 | 07 - 16 | 15,000 | 13.00 | 42 x 41 x 24 |
| SH6028 | 1500 | 900 | 13 - 16 | 9,000 | 6.40 | 38 x 37 x 22 |

AR-001A

SPECIFICATION FOR APPROVAL

REF : 20091008-A

PAGE: 4

| | | | |
|------------|--------------------------------|----------------|------------------|
| PROD. NAME | SHIELDED SMD POWER INDUCTOR | ABC'S DWG NO. | SH6028□□□□L□-□□□ |
| | | ABC'S ITEM NO. | |

VII . DWGING NUMBER EXPRESSION :

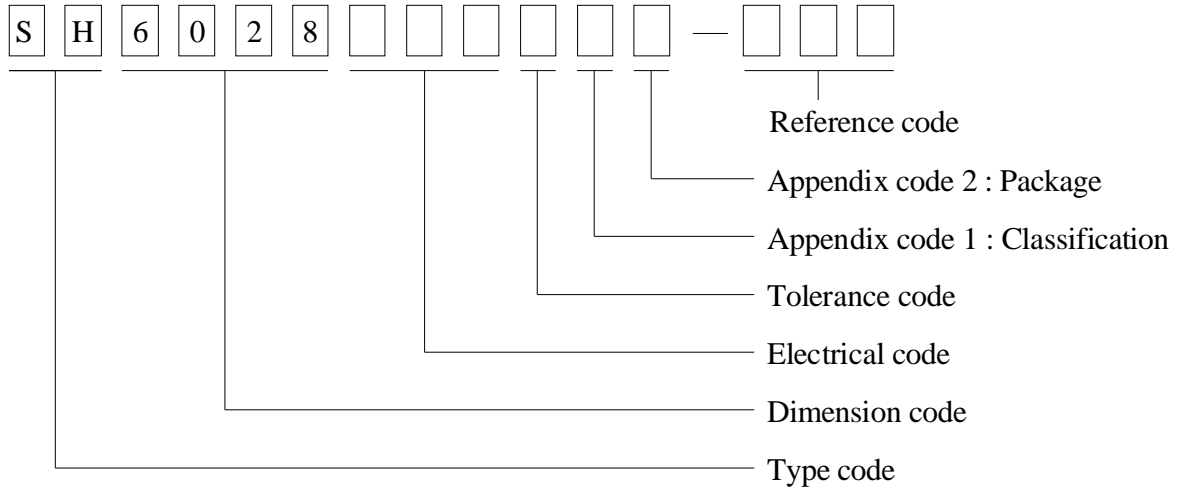

Appendix code 1 : Product Classification

- L : Lead Free Standard products comply with RoHS' requirements
- 1 ~ 9 : Lead Free Special products comply with RoHS' requirements

Appendix code 2 : Package Information

| Code | Inner package | Inner package Q'TY | Remark |
|------|------------------------|--------------------|--------|
| A | T.B.D. | T.B.D. | |
| B | T / R (Reel package) | 500 pcs | |
| C | T / R (Reel package) | 1500 pcs | |

SPECIFICATION FOR APPROVAL

REF : 20091008-A

PAGE: 5

| | | | |
|---------------|--------------------------------|----------------|------------------|
| PROD. NAME | SHIELDED SMD POWER INDUCTOR | ABC'S DWG NO. | SH6028□□□□L□-□□□ |
| | | ABC'S ITEM NO. | |

VIII . RELIABILITY TEST :

| Test item | Specification | Test condition | | | | | | |
|---------------------------------------|---|---|--------------------------|---|----------------------|--------------------------|---|-----------------------|
| Solderability | More than 95% of the terminal electrode Shall be covered With fresh solder. | Preheat : 155°C / 4 hours. Solder : Sn96.5 / Ag3 / Cu0.5 or equivalent Solder temp. : 235±5°C Flux : Rosin Dip time : 5±0.5 seconds | | | | | | |
| Thermal shock test (Temp. cycle) | Electrical oharacteristics shall not change more than ±20% | <table style="width: 100%; border: none;"> <tr> <td style="border: none;">Room temp. 15 minutes</td> <td style="border: none; text-align: center;">→</td> <td style="border: none; text-align: center;">-40 °C 30 minutes</td> </tr> <tr> <td style="border: none;">Room temp. 15 minutes</td> <td style="border: none; text-align: center;">→</td> <td style="border: none; text-align: center;">+105 °C 30 minutes</td> </tr> </table> <p>Total : 50 cycles</p> | Room temp. 15 minutes | → | -40 °C 30 minutes | Room temp. 15 minutes | → | +105 °C 30 minutes |
| Room temp. 15 minutes | → | -40 °C 30 minutes | | | | | | |
| Room temp. 15 minutes | → | +105 °C 30 minutes | | | | | | |
| Humidity test | | Temperature : 40±2°C Humidity : 90±5% Time : 1000 hours | | | | | | |
| High temp. Resistance test | | Temperature : 105±5°C Applied current : Per spec. Time : 96 hours | | | | | | |

AR-001A



SPECIFICATION FOR APPROVAL

REF : 20091008-A

PAGE: 6

| | | | |
|---------------|--------------------------------|----------------|------------------|
| PROD. NAME | SHIELDED SMD POWER INDUCTOR | ABC'S DWG NO. | SH6028□□□□L□-□□□ |
| | | ABC'S ITEM NO. | |

IX . UL CARD :

| OBMW2 | | October 06, 2005 | | | |
|--|--------------|-----------------------------|-------|-----------------|-------------|
| Magnet Wire-Component | | | | | |
| ELEKTRISOLA (MALAYSLA) SDN BHD | | | | | E143312 |
| JALAN DAMAI SATU JANDA BAIK 28750 BENTONG, PAHANG DARUL MAKMUR MALAYSIA | | | | | |
| Mtl Dsg | Mark Dsg | Coating Type | | ANSI Typ | Temp Class |
| | | BC | OC | | |
| Estersol 180 | E180 | Polyesterimide (solderable) | — | MW-77 | 180 |
| Amldester 200 | A200 | Polyesterimide | — | MW-74 | 200 |
| Polysol-N 155 | PN155 | Polyurethane | Nylon | MW-80, MW-28 | 155, 130 |
| Polysol 155 | P155, G155 | Polyurethane | — | MW-79, MW-75 | 155, 130 |
| Polysol 155g | Pg155 | Polyurethane | — | MW-75 | 130 |
| Polysol 155p | Pp155,Gp155 | Polyurethane | — | MW-79 | 155 |
| Polysol 160 | P160 | Polyurethane | — | MW-79 | 155 |
| Polysol 180 | P180,G180 | Polyurethane | — | MW-82 | 180 |
| | | | — | MW-79 | 155 |
| Polysol 170 | P170 or G170 | Polyurethane | — | MW-79 | 155 |
| Polysol-N 180 | PN180 | Polyurethane | Nylon | MW-83 | 180 |
| Polysol P155p | P155p | | — | MW-79 | 155 |

Marking : Company name, material designation or marked designation and factory identification on package ok reel

See General Information preceding These Recognitions
For use only in equipment where the acceptability of the combination is determined by Underwriters Laboratories Inc.