



SPECIFICATIONS

CONTACT RATING: Dependent upon contact material.
MECHANICAL LIFE: 30,000 make-and-break cycles.
CONTACT RESISTANCE: 20mΩ max. initial @ 2-4VDC
 100mA for both silver and gold plated contacts.
INSULATION RESISTANCE: 1,000MΩ min.
DIELECTRIC STRENGTH: 1,000 V RMS@sea level.
OPERATING TEMPERATURE: -30°C to 85°C

MATERIALS

CASE & BUSHING - Glass filled nylon 4/6, flame retardant, heat stabilized (UL 94V-0)
ACTUATOR - Brass, chrome plated, internal O-ring seal. Standard for all actuators.
SWITCH SUPPORT - Brass, tin plated.
CONTACT/TERMINALS - Copper alloy, with Silver or gold plated. (See Page 40)

HOW TO ORDER

2B Sealed Sub-Miniature Toggle Switches(SMT)

MODEL NO. ACTUATOR BUSHING TERMINATIONS CONTACT MATERIAL SEAL ROHS SOLDERING

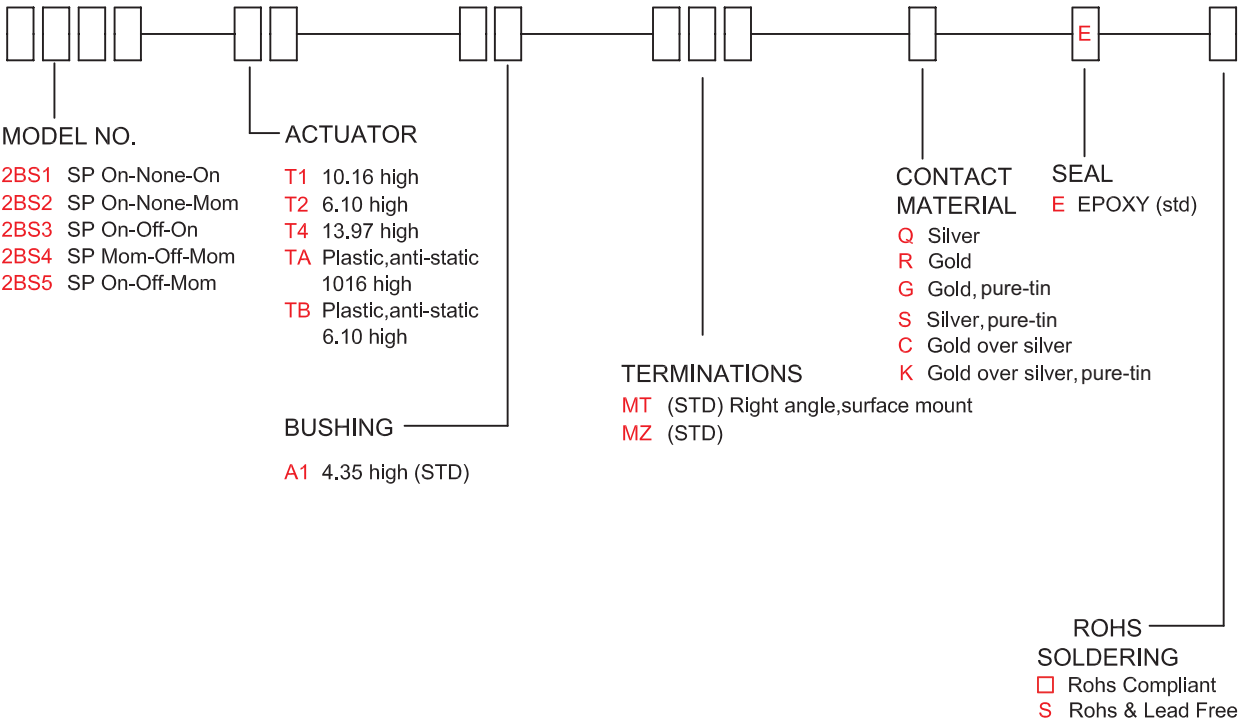

SWITCH FUNCTION

NO. POLES	UL-CSA	MODEL NO.	SWITCH FUNCTION			CONNECTED TERMINALS / SCHEMATIC		
			POS.1	POS.2	POS.3	POS.1	POS.2	POS.3
SP	Q22B11	2BS1	ON	NONE	ON		OPEN	
	Q22B12	2BS2	ON	NONE	MOM			
	Q22B13	2BS3	ON	OFF	ON			
	Q22B14	2BS4	MOM	OFF	MOM			
	Q22B15	2BS5	ON	OFF	MOM			

POLE OPTIONS

MT

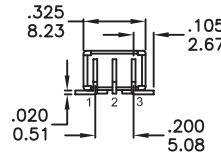
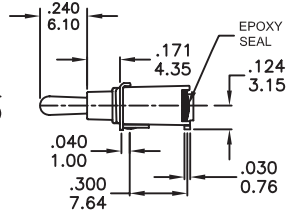
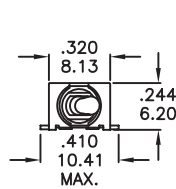

P.C. MOUNTING

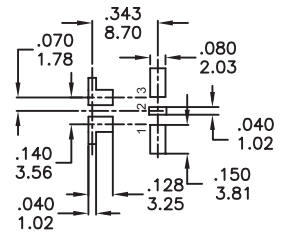

SPDT

Part No. shown : 2BS1T2A1MTRE

MZ

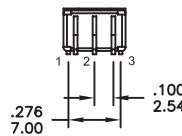
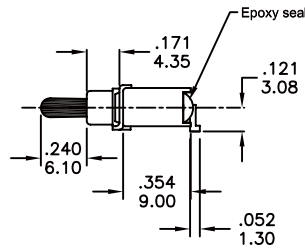
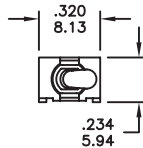

P.C. MOUNTING

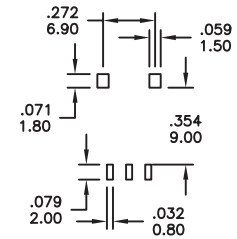

SPDT

Part No. shown : 2BS1TBA1MZRE

ACTUATOR OPTIONS

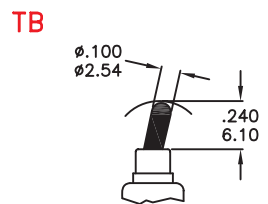
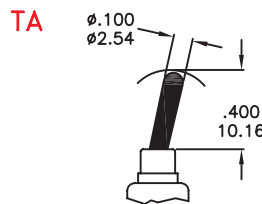
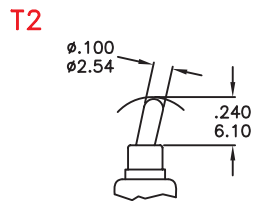
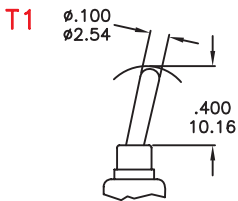

ESD PLASTIC ACTUATOR

PACKAGING

Switches available on embossed antistatic tape and reels.
Tape and cover strip are conductive for use near statically sensitive components.

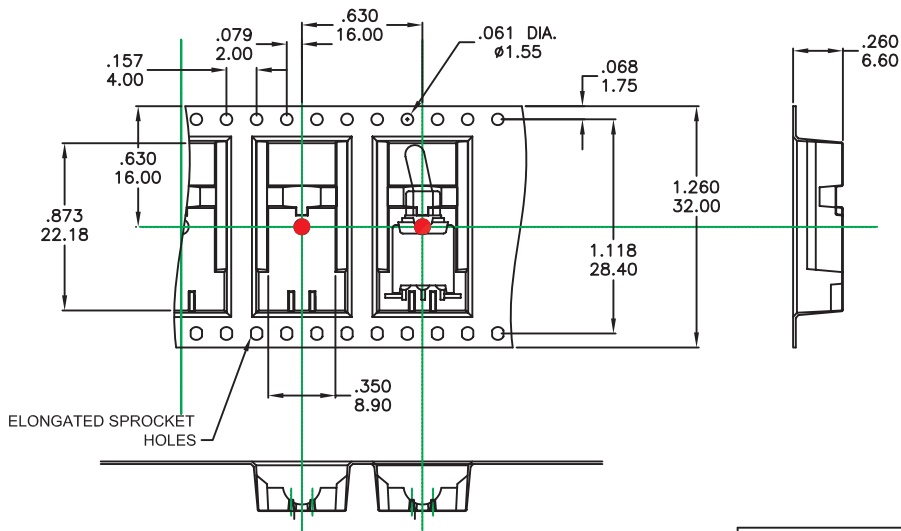
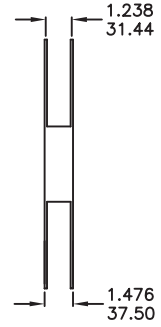
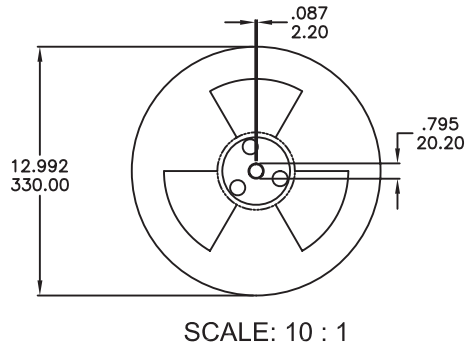

REEL INFORMATION	
QUANTITY PER REEL	500 PCS

CONTACT MATERIAL OPTIONS

	CONTACT MATERIAL	TERMINAL PLATING	RATINGS
Q	Silver	Q = Gold flash over silver	3 Amps with resistant load @ 120VAC or 28VDC 1 Amps with resistant load @ 250VAC
S		S = Gold flash over silver,pure - tin	
C	Gold over Silver	C = Gold over silver	
K		K = Gold over silver,pure - tin	
R	Gold	R = Gold	0.4 Volt-Amps(VA)max. @ 20V max. (AC or DC)
G		G = Gold,pure - tin	



IP 67
ACCORDING TO
EN 60529:1991+A1:2001
IEC 60529:2001

SOLDERING PROCESSES

WAVE SOLDERING : Recommended Soldering Temperature:260±5°C
Duration of Solder Immersion: 5 ±1 seconds
(PCB is 1.6mm in thickness)

SOLDERING : Vapor phase & IR- reflow soldering can be applied.

Temperature Profile

Zone	Room temperature	Time (Sec)
Pre-heat (A)	150°C	Min 120s
Soak (B)	180°C~200°C	Min 150s
Peak (C)	200°C~235°C	Min 30s
Peak (D)	235°C~260°C	Min 40s
Peak (E)	260°C	Max 10s

